

# classic

by

TANNING  
essentials



## SIMPLY UNCOMPLICATED TANNING SYSTEMS

Training Manual

TANNING  
essentials

SIMPLY UNCOMPLICATED TANNING SYSTEMS

Australia • China • United Kingdom • USA

# WELCOME

Thank you for choosing the Tanning Essentials Classic Spray Tan System. Please read the following to enjoy your new system for many happy tanning applications.

## QUICK SET UP GUIDE

The Tanning Essentials Classic Spray Tan System contains the following:

- |   |                        |   |                              |
|---|------------------------|---|------------------------------|
| 1 | 1 x Classic Spray Unit | 2 | 1 x Classic Spray Applicator |
| 3 | 1 x Classic Spray Hose | 4 | 1 x Power Cord               |
| 5 | 1 x Manual             |   |                              |

\* Additional solution cups with lids can be purchased through your dealer to conveniently change solutions and keep solution air tight.



# SPRAY SYSTEM

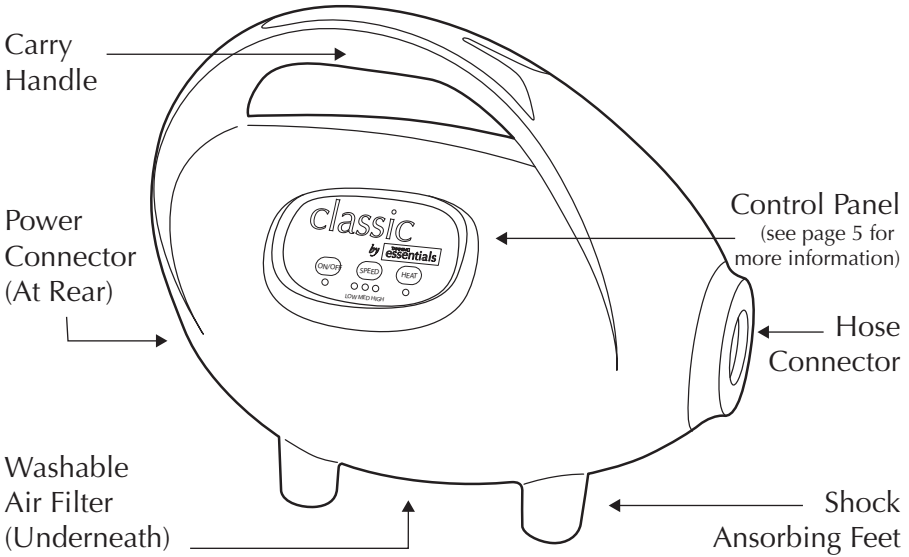

# SPRAY APPLICATOR

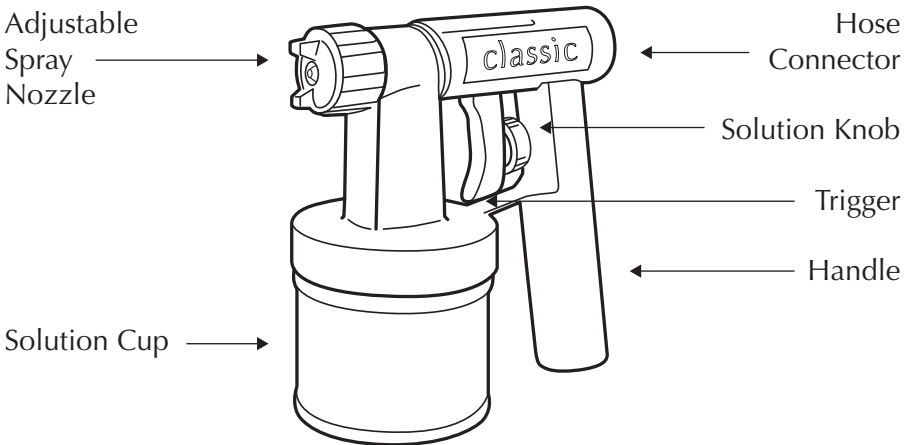

# SPRAY APPLICATOR



## STEP 1

Unscrew solution cup and Fill Solution Cup no more than  $\frac{1}{2}$  -  $\frac{3}{4}$  full. Over filling the solution cup may cause the cup to leak.



## STEP 2

Insert Cup into applicator and screw tightly. Being careful not to cross thread the solution cup

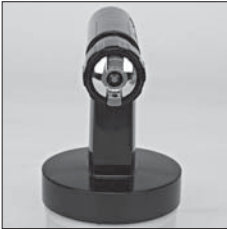

## STEP 3

Set the spray pattern by turning the silver nozzle, aligning the nozzle in a vertical position for up/down spraying and horizontal position for left to right spraying.



## STEP 4

Adjust Solution Dial behind the trigger to desired level. Start with the dial hard against the trigger resulting in maximum solution spraying from the applicator, then wind out until the desired result is obtained.



## STEP 5

Attach Hose. Insert the hose into the back of the spray applicator until firmly in place.

# SPRAY UNIT



## STEP 1

Attach Hose to Unit. Insert hose into the unit with the bayonet style fitting and turn anti-clockwise until firmly in place. Avoid over tightening as this may result in broken components.

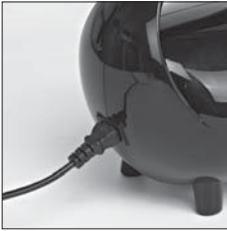

## STEP 2

Attach power cord and turn power on at the wall switch.



## STEP 3

Turn the unit on and start spraying. The unit is controlled via three buttons on the front of the Spray Unit (see below).

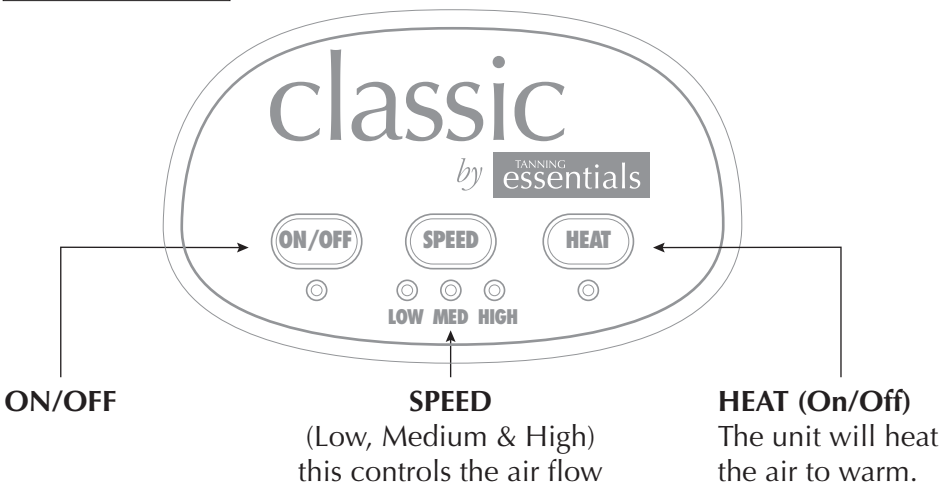

The most common setting is Medium air flow with heat On.

# MAINTENANCE GUIDE

## SPRAY APPLICATOR

- Step 1** Remove hose.
- Step 2** Unscrew solution cup and empty any excess solution. It is recommended that this be done over a sink or a wet area.
- Step 3** Rinse the empty solution cup with warm water.
- Step 4** With warm water in the solution cup, spray the water through the applicator. Use the highest setting for maximum water spraying when cleaning.
- Step 5** Empty solution cup and re-set the solution dial on the back of the gun to the regular spray setting.
- Step 6** Wipe any excess water from the applicator with a cloth and warm water.

## SPRAY UNIT

- Step 1** Clean the Spray Unit with a cloth. Avoid using anything abrasive. Windex and Mr. Sheen are useful products for maintaining the gloss finish on your Spray Unit.
- Step 2** Clean the filter. Remove the filter from the base of the unit and rinse in warm water. Wait until filter is completely dry before re-fitting. Positioning the spray unit behind the spray technician when in use will ensure the unit stays cleaner for longer.

# TROUBLE SHOOTING

If you experience problems with this unit, in the first instance please read carefully the relevant sections of this User Manual and this Trouble Shooting section. If you can not solve your problem please contact your supplier via phone for assistance.

<b>Problem</b>	<b>Cause</b>	<b>What to do</b>
The Spray Unit will not turn on	Power cord not attached	Ensure that the power cord is pushed in firmly to the base of the unit and wall socket
	Electricity not turned on	Ensure the power point is on
	The unit is not turned on	Press the On/Off Button on the control panel and watch for the LED light to indicate ON.
The spray applicator is leaking	Spray Cup is not tight enough	Tighten the solution cup
	Solution cup seal missing	Insert the rubber cup seal
	Too much solution	Empty some solution from the spray cup
	Nozzle may be blocked	Spray warm water through the applicator
The spray is spluttering	Solution cup low	Add solution to the cup
	Air speed is set too low	Check the filter for blockages
	Angled applicator too sharply while spraying	Keep the applicator on a lesser angle while spraying
	Nozzle may be blocked	Spray warm water through the applicator
	Filter could be blocked	Ensure the filter underneath the Spray Unit is clean
	Spray applicator control dial is set too low	Wind in solution knob below the hose connector of the gun

<b>Problem</b>	<b>Cause</b>	<b>What to do</b>
No solution is coming out of the spray applicator	Nozzle may be blocked	Spray warm water through the applicator
	Solution cup low	Add solution to the cup
	Trigger is jamming	Spray warm water through the applicator repeatedly ensuring the Solution Dial is allowing maximum water through the applicator
	Solution Dial on applicator set too low	Wind in the solution dial on applicator
The applicator is continuing to spray	Trigger or nozzle is jamming	Spray warm water through the applicator repeatedly ensuring the Solution Dial is allowing maximum water through the applicator
Hose coming out of unit	Hose not correctly fitted to unit	Ensure the fitting is inserted and quick connect fitting is locked into place.
	Hose fitting broken from over tightening	Contact your supplier or service agent



# TIPS AND TRICKS

Problem	Cause	What to do
The solution is sitting on the skin or beading on the client	Too much tanning solution has been sprayed onto the skin	Dab area gently with a clean dry towel and re-spray lightly, blending the tan in
	Client has not prepared their skin correctly i.e. moisturiser or perfume on the skin	
	Client maybe excessively hot and perspiring	
The client has tanning solution in areas they don't wish to tan	The technician has sprayed the area incorrectly	Exfoliate the area using tan removing product for best results or a cloth and soap
	Client has touched part of their body with a spray tanned area	
The client appears orange	Too much tanning solution has been sprayed onto the skin	Exfoliate the skin before re-spraying and ensure the spray application is lighter
	The client may have left a rapid tanning solution on too long	
	The client may have low toleranceto DHA	
The spray tan has not developed as dark as desired	The spray tan solution used may be old or heat affected reducing the reaction in the skin. Sometimes a green hue will appear to indicate this	<p>Be sure to keep the solution in a cool dry place and ensure the solution is fresh.</p> <p>Ensure the client has followed the correct recommendations for preparation and post spray tan care.</p> <p>The client can be resprayed if required after their minimum 8 hours and after a shower has been taken</p>
	A different solution was sprayed or the spray application dial was set lighter	
	The client may have showered or perspired before the tan could develop	
	Other factors may affect the tan's development, including diet, hormones and medication. Please refer to the client	

# WARRANTY INFORMATION

## IMPORTANT

**Please keep your proof of Purchase and User Manual in a safe place as you will require these to make a warranty claim. Prior to making a claim you should read through the trouble shooting section in the manual and contact your supplier via phone. Any warranty claims should be made directly to your supplier.**

If within one (1) year from the date of purchase, the product fails due to a defect in material or workmanship, we will repair if possible or replace it free of charge with a comparable unit which may be new or refurbished. This warranty applies only to the original purchaser and is not transferable. The goods must be returned to the seller with proof of purchase to be assessed at the purchasers cost.

Warranties shall not apply to any defect, failure or damage caused by improper use or improper or inadequate maintenance and care. The manufacturer shall not be obligated under these warranties:

- a) to repair damage resulting from attempts by personnel other than authorised representatives to install, repair or service the product,
- b) to repair damage, malfunction, or degradation of performance resulting from improper use or incompatible solution,
- c) to perform maintenance or cleaning or to repair damage, malfunction, or degradation of performance resulting from failure to perform user maintenance and cleaning as prescribed,
- d) to repair damage, malfunction, or degradation of performance resulting from use of the product in an environment not meeting the operating specifications,

To activate your warranty, please complete the information below and post to your supplier within 14 days of purchase.

# SAFETY INFORMATION

The Tanning Essentials Classic Spray Tanning System is designed and built to the highest standards. This system must not be operated by children, sprayed using only professional spray tan solution, kept away from water and be connected to the correct power supply at all time.

Please note the details of your model here:

Model:  Pro  Classic  Mini

Serial Number:

Date of Purchase:

Supplier Name:

The Tanning Essentials Classic Spray Tanning System is made in China



# WARRANTY CARD



Model Type:  Serial Number:

Supplier Name:  Date Of Purchase:

Name:

Address:  Suburb:

Post Code:  State:  Country:

Email:  Phone:

Business Type:  Beauty  Tanning  Hair  Mobile  Home

To submit your warranty online, please visit [www.tanningessentials.co](http://www.tanningessentials.co) and select the warranty link.



Australia • China • United Kingdom • USA

10 Apex Court, Thomastown, VIC. 3074 Australia  
t: 1300 877 677 (within Australia) • int: +613 9463 8900  
email sales@tanningessentials.co

[www.tanningessentials.co](http://www.tanningessentials.co)



AFFIX  
POSTAGE  
STAMP  
HERE

Tanning Essentials  
10 Apex Court,  
Thomastown, VIC. 3074  
Australia