

TANNING essentials®

PROV APPLICATOR MAINTENANCE

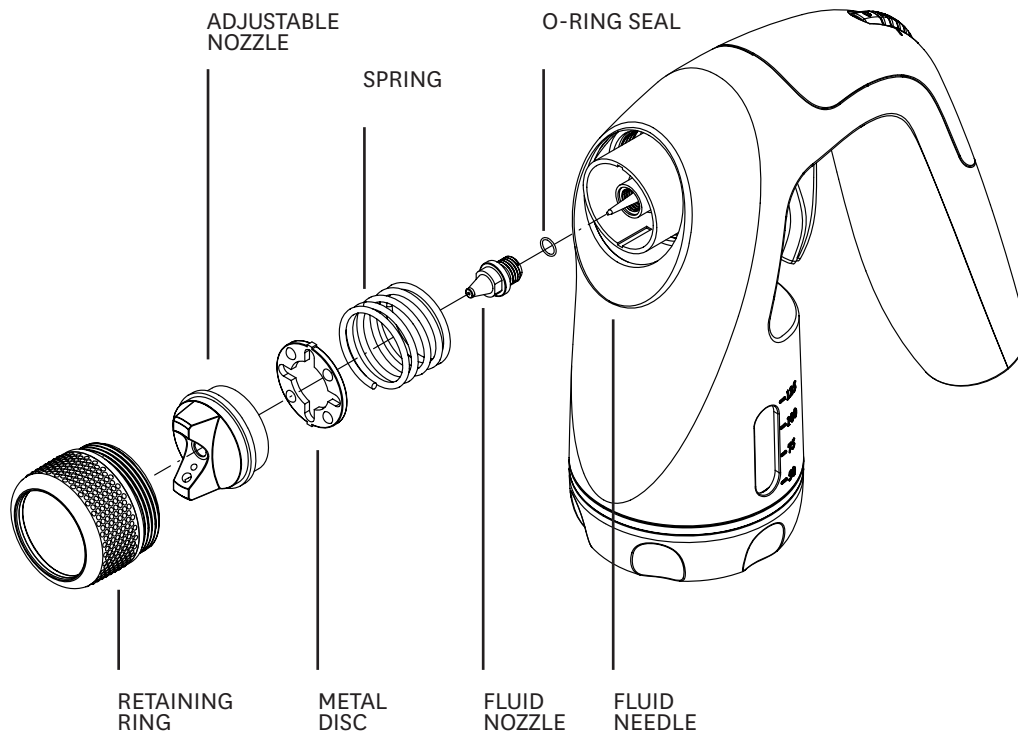

TROUBLESHOOTING - BLOCKED NOZZLE OR CONTINUOUS SPRAY WITHOUT PRESSING THE TRIGGER

- STEP 1** Locate and unscrew retaining ring. To release; turn retaining ring in an anti-clockwise motion.
- STEP 2** Gently pull on the adjustable nozzle to remove.
- STEP 3** Gently remove the metal disc and spring.
- STEP 4** Fit an 8mm spanner to the flat edges of the fluid nozzle and turn anti-clockwise to unscrew.
- STEP 5** Ensure you do not misplace the o-ring seal, which is located behind the fluid nozzle .
- STEP 6** Once removed, visually inspect the fluid nozzle for small particles or blockages - rinse thoroughly with hot water.
- STEP 7** Gently wipe the fluid needle to clean and remove any debris.
(the fluid needle should not be removed from the applicator at any time)
- STEP 8** Once visually clear of any debris, re-attach fluid nozzle, ensuring the O-ring is in position, then use the spanner (8mm) to gently tighten back into place.
- STEP 9** Replace spring, then gently insert metal disc ensuring the grooves on the disc line up with the sides and the raised front is forward facing.
- STEP 10** Replace adjustable nozzle and rotate back into position.
- STEP 11** Repeat previous step, this time with the retaining ring.